

Praweda Ciptakarsa Informatika Soedarpo Informatika Group

bringing the right IT Solution for your Company



Shanti-L.Poesposoetjipto
Soedarpo Informatika
Jakarta, Indonesia



Asia-Pacific
Information Technology
Summit

Soedarpo Informatika in Brief

Started by Soedarpo Sastrosatomo, a visionary indigenous Indonesian Entrepreneur in 1952, importing RCA telecommunication equipment's spare parts and Remington Rand typewriters, who went into the IT Business in 1958 as the authorized sole distributor of UNIVAC computer system.

Today it is a brand name of all Information Technology companies owned by the Soedarpo family



Asia-Pacific

Information Technology

Summit

Soedarpo Informatika in Brief

* PT. Jasa Jejaring Wasantara

- Provides Internet solutions from consultation, designing, implementation, maintenance, and training
- Provides Internet access

* PT. Sumber Daya Proweda Informatika

- Provides specialized IT solution including customized software and hardware



Soedarpo Informatika in Brief

* PT. Praweda Ciptakarsa Informatika

- Provides IT solutions for financial industry in banking and non-banking sectors
- Provides IT solutions for government and public sectors
- Provides IT solutions in the field of communication and networking



Our Solutions...

PAYMENT SYSTEM DEVISION account group 1

A

Payment System Solution

Application

- Clearing System :
 - Clearing application
 - Clearing with Image based application
 - Electronic clearing
 - Intercity clearing
- High Value Payment System
- Financial application
- Executive Information System

Scope of work

- Development, customizing, migration, modification application.
- Integrate system
- Hardware - Network install and set up.

B

Payment System Services

Consultation

- Payment system policy & system procedures
- Financial, MIS
- Network, IT Infrastructure

Project Management

- Define user requirement and functional specifications.
- Implementation and user training
- System integrator
- Out sourcing

Maintenance

On side system support for Hardware, Software

C

Payment System Skill

Programming :

- Language : 3rd GL, 4th GL
- Tools : Visual Basic, Visual C++
- Database : RDBMS

Operating System

- Windows, Windows NT, OS2, SCO Unix,

Network

- TCPIP, SNA, X.25
- LAN, WAN, INTERNET
- VSAT

Our Partners...

PAYMENT SYSTEM DEVISION
account group 1

A

SOLUTIONS

Partners

- BCSIS
- AFS
- UNISYS
- SWIFT
- NCR

B

CONSULTING

Partners

- BCSIS
- BSA
- KPMG
- Consultancy Associates

C

VENDOR

Partners

- IBM
- UNISYS
- NCR
- COMPAQ

- READER ENCODER :
 - UNISYS
 - NCR
 - FUJI
 - MKL

Blueprint of the Indonesian National Payment System

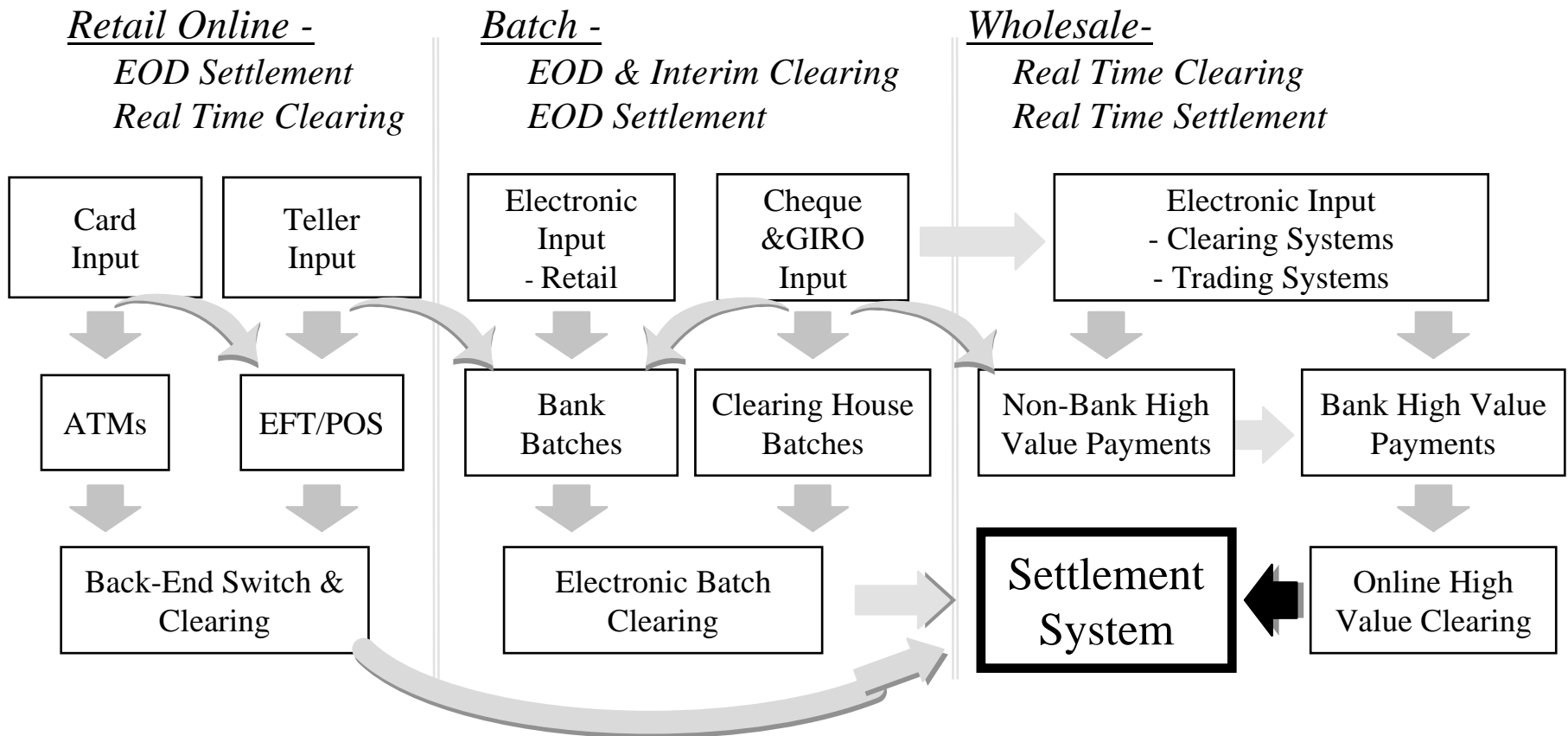

mid 1997 : 1.1 Million Credit Cards issued

4.8 Million ATM cards issued, 2.600 ATMs installed

JAKARTA - ELECTRONIC CHEQUES CLEARING SYSTEM

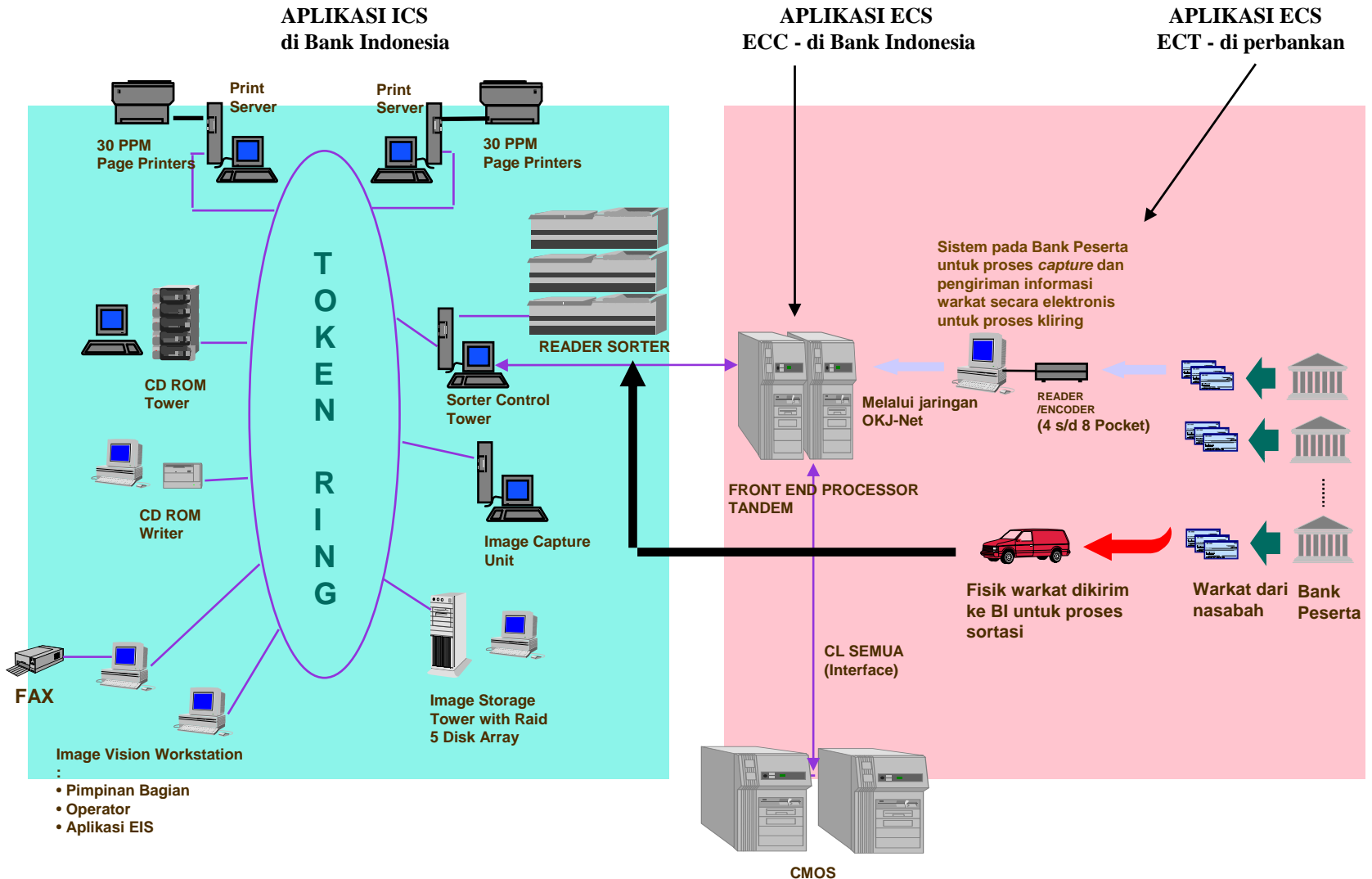

Our Solutions...

PUBLIC SECTOR
DIVISION

A Application Development Solution

Tailor Made

- 3 rd GL Programming
- 4th GL Programming
- Client Server Architecture
- Advanced Program to Program Communication

Standard Application Modification

- Personnel (Gov.. Standard)
- Accounting, Inventory

Migration/ Conversion

- Different Platform Conversion
- Flat file to Database Conversion

B Project Management Service

Methodology Approach

C System Support Service

Multiple Platform

- UNIX - RISC
- Microsoft 95/98/NT
- AS/400

D Other Services

Consultation

Training

Technical Support

Outsourcing

Our Partners...

PUBLIC SECTOR DIVISION

A

LAN/WAN Partners

- CISCO SYSTEMS
- Ascom Timeplex
- Microcom
- US Robotics/3COM
- Hayes
- JRC
- AMP

B

Internetworking Partners

- PACIFIC INTERNET
- APJII
- INDOSAT
- TELKOM
- LINTAS ARTA
- RATELINDO
- CSM

C

Other Partners

- IBM
- UNISYS
- DUN & BRADSTREET
- MICROSOFT
- COMPAQ
- SATYAM
- GMT-2000
- MEMOREX TELEX
- SYBASE

PT. Praweda Ciptakarsa Informatika

N&T Division - SNA to TCP/IP Migration *Project*

- *Ministry of Religious affairs 1995 -*

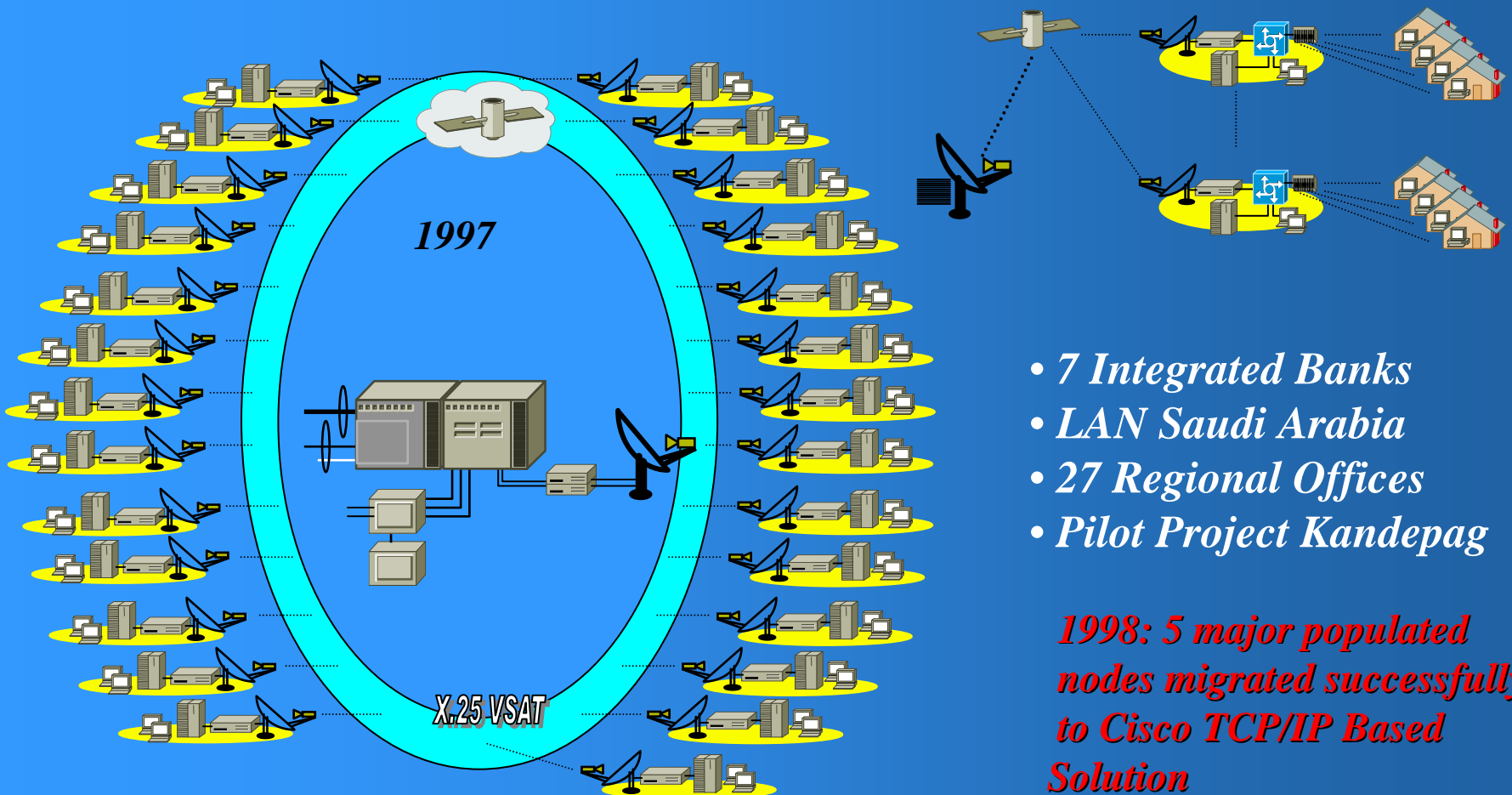

HAJ MOVEMENT MONITORING SYSTEM

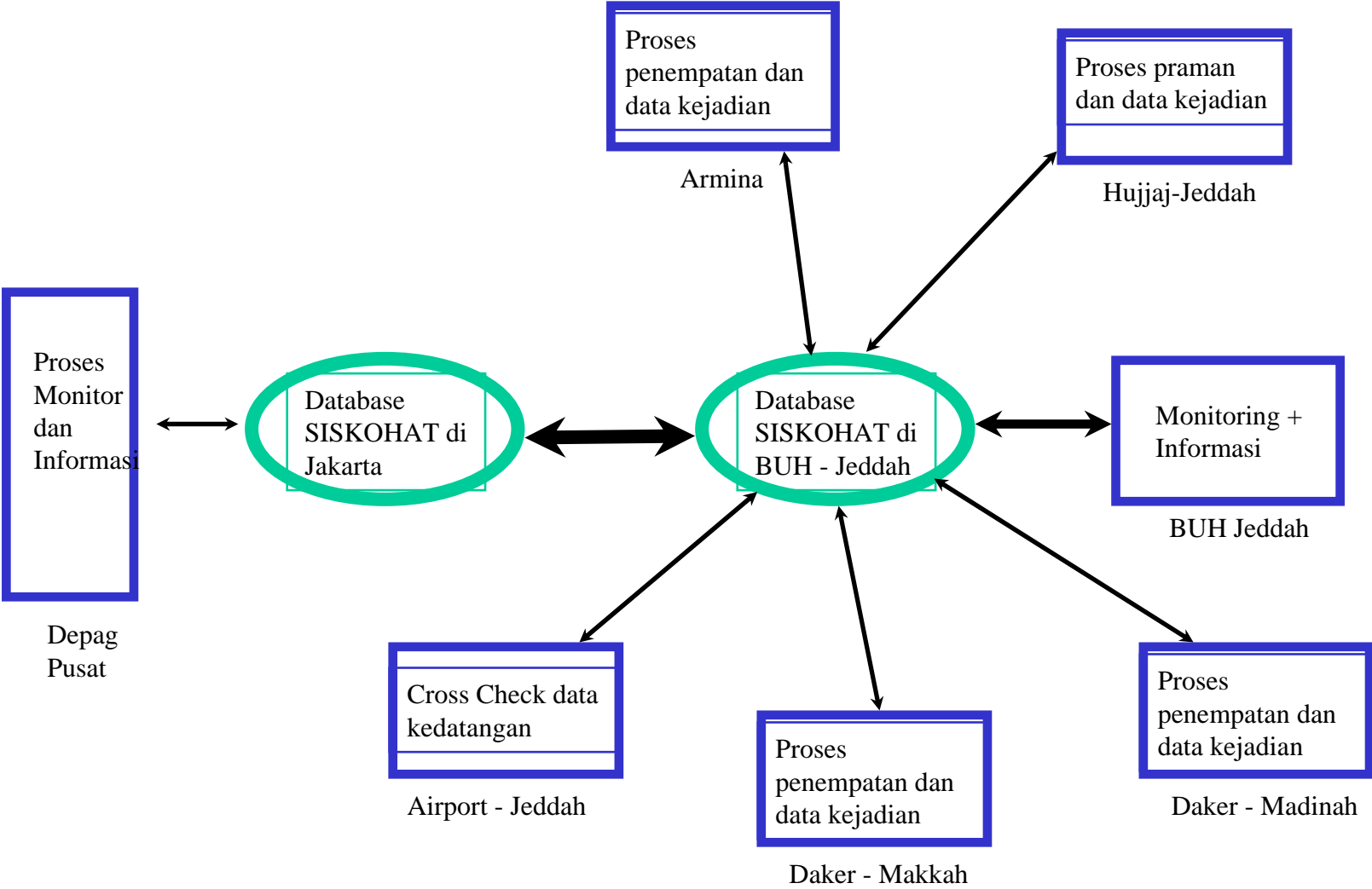

Our Solutions...

NETWORK AND TELECOMMUNICATION DIVISION

A

LAN/WAN Solution

LAN

- All interconnectivities within one local area Network such as peer to peer connections, workgroup and local e-mail

WAN

- All interconnectivities within Wide Area Network such as connection among Head Office and Regional Offices and File transfer

Telecommunication

- Radio Communications
- Cabling
- Fiber Optic
- CDPD/Wireless Data Communications
- MUX
- Voice Integration

B

Internetworking Solution

Internet

- Internet Access
- Web Development
- Web Hosting
- E-mail services
- File Transfer Protocol
- Ad Link
- Domain Name Server

Intranet

All Internet applications which are developed for internal use only for maximum securities

Extranet

Access from outside to the Corporate Intranet such as telecommuters

C

Other Services

Consultation

- Network Solution and Configuration
- Year 2000 Compliance

Training

- In House Customized Training

Seminar Maintenance

- Contract Maintenance
- On Call Maintenance

Our Partners...

NETWORK AND TELECOMMUNICATION DIVISION

A

LAN/WAN Partners

- CISCO SYSTEMS
- MICROCOM
- Ascom Timeplex
- US ROBOTICS
- HAYES
- JRC
- AMP

B

Internetworking Partners

- PACIFIC INTERNET
- APJII
- INDOSAT
- TELKOM
- LINTAS ARTA
- RATELINDO
- CSM

C

Other Partners

- IBM
- UNISYS
- DUN & BRADSTREET
- MICROSOFT
- COMPAQ
- SATYAM
- GMT-2000
- MEMOREX TELEX
- SYBASE

PT. Praweda Ciptakarsa Informatika

N&T Division - *Project*

- *Bank Indonesia - BI-net Blueprint 1994*

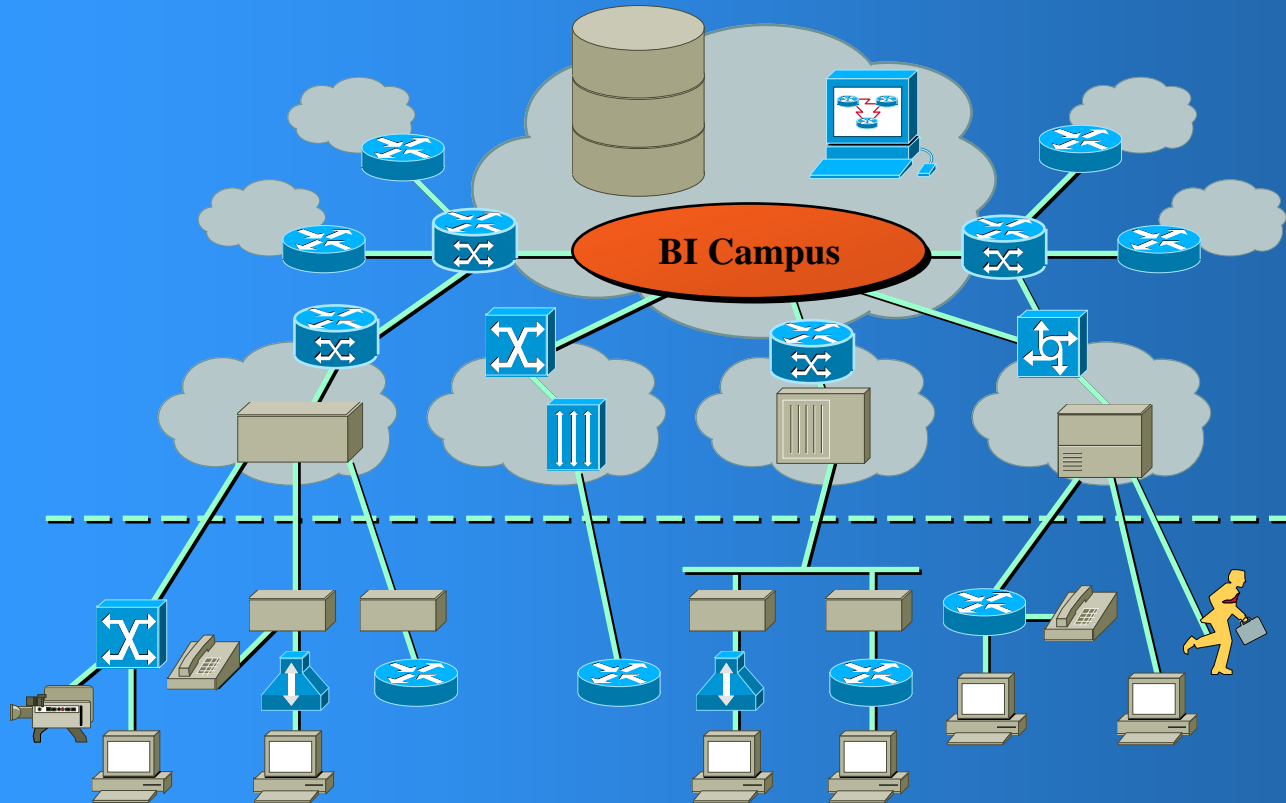

PT. Praweda Ciptakarsa Informatika

N&T Division - *Project*

- *ISP (SONET), TELKOM Risti 1994-1995*

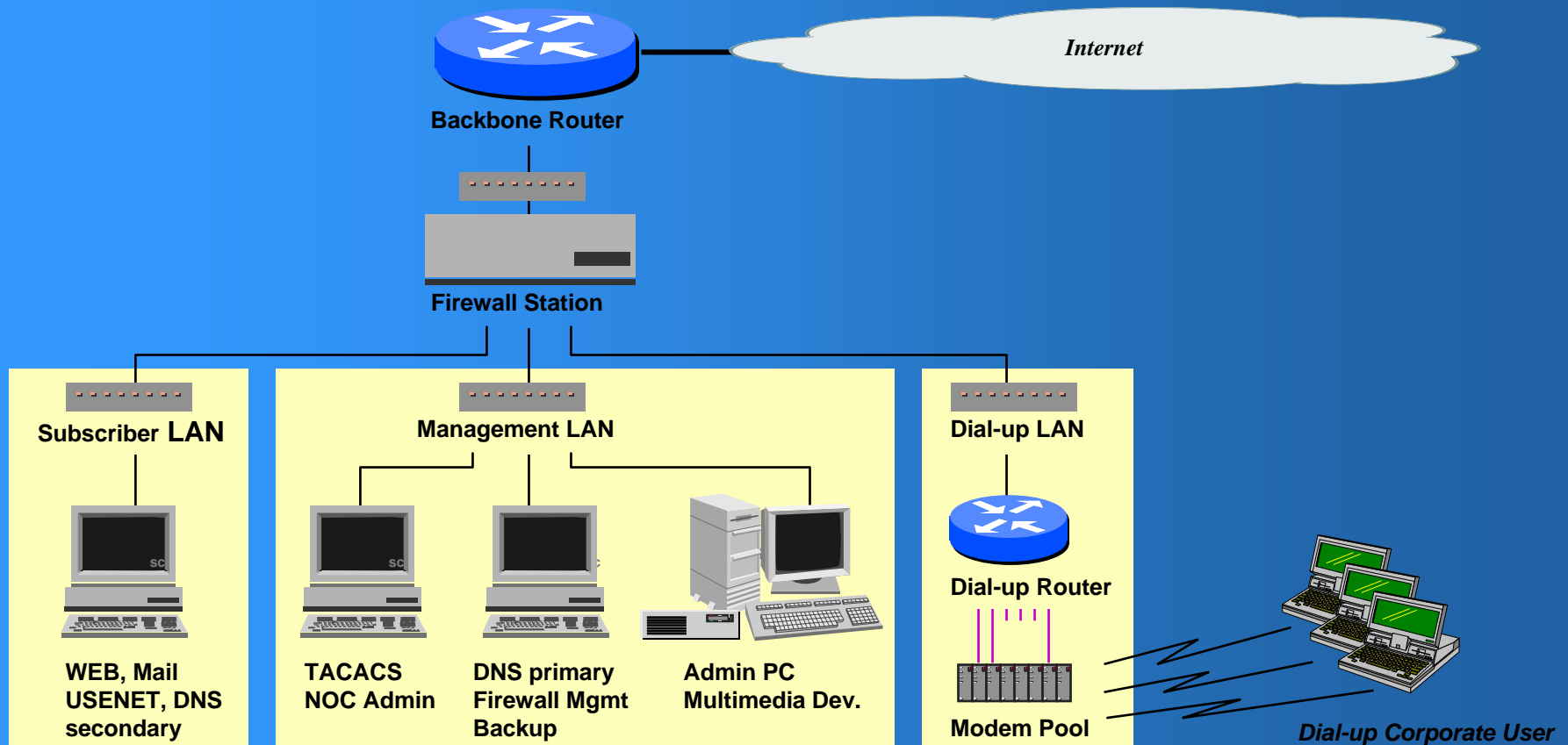

PT. Praweda Ciptakarsa Informatika

N&T Division - *Development - ISDN PRI*

Hybrid Dial PSTN - Pasopati

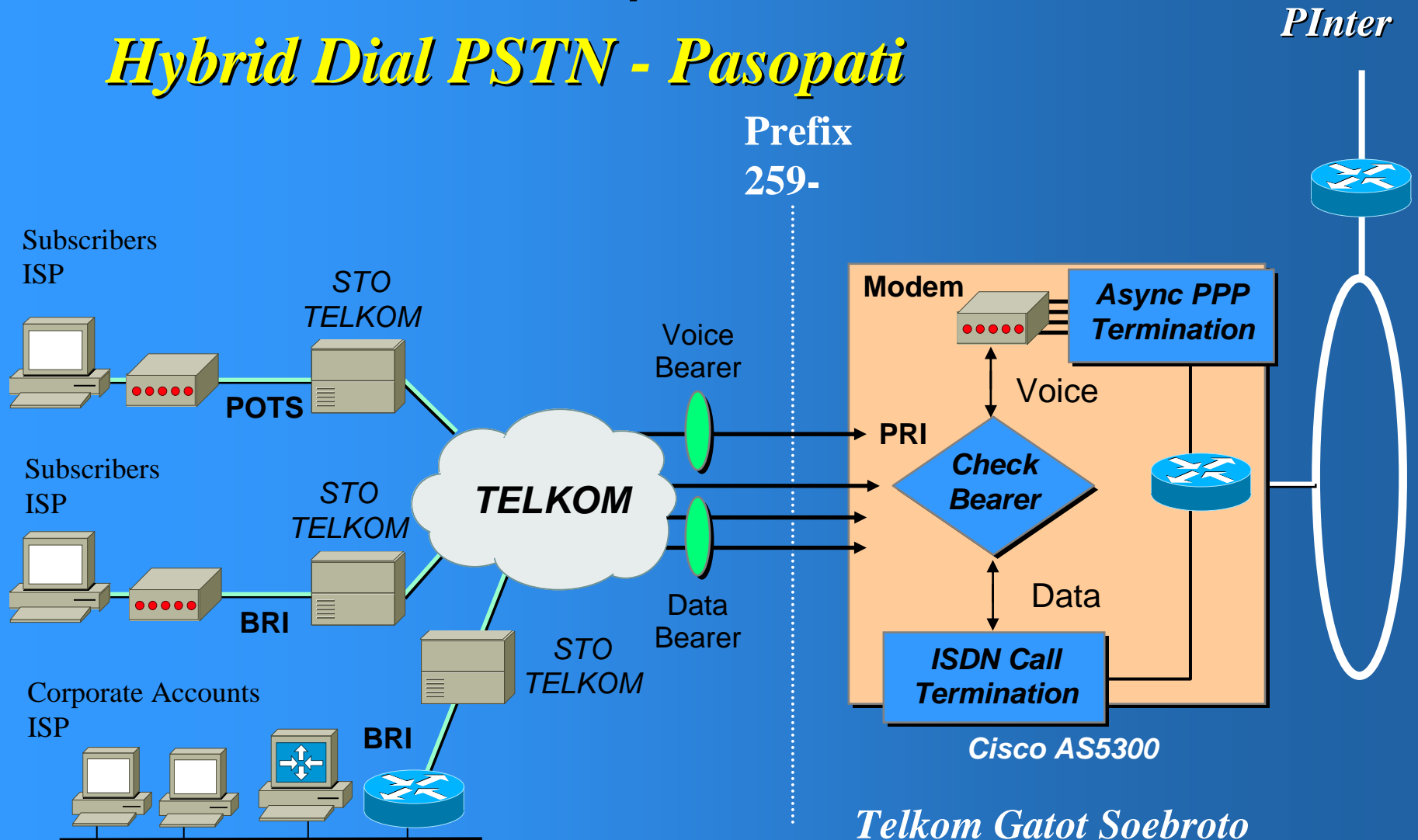

Telkom Gatot Soebroto

PT. Praweda Ciptakarsa Informatika

N&T Division - *Network Development*

Virtual Private Network

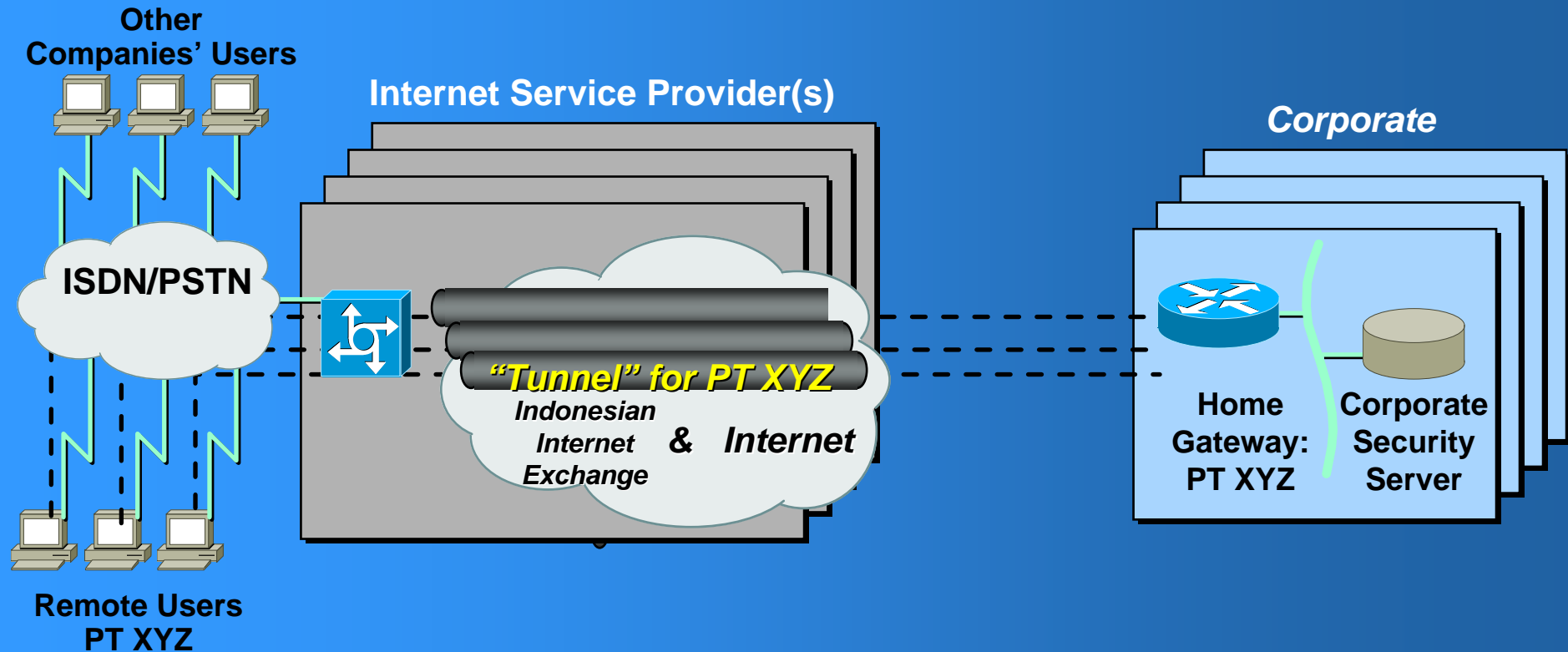

PT. Praweda Ciptakarsa Informatika

N&T Division - *Network Development*

Wireless Network Access - JAKARTA

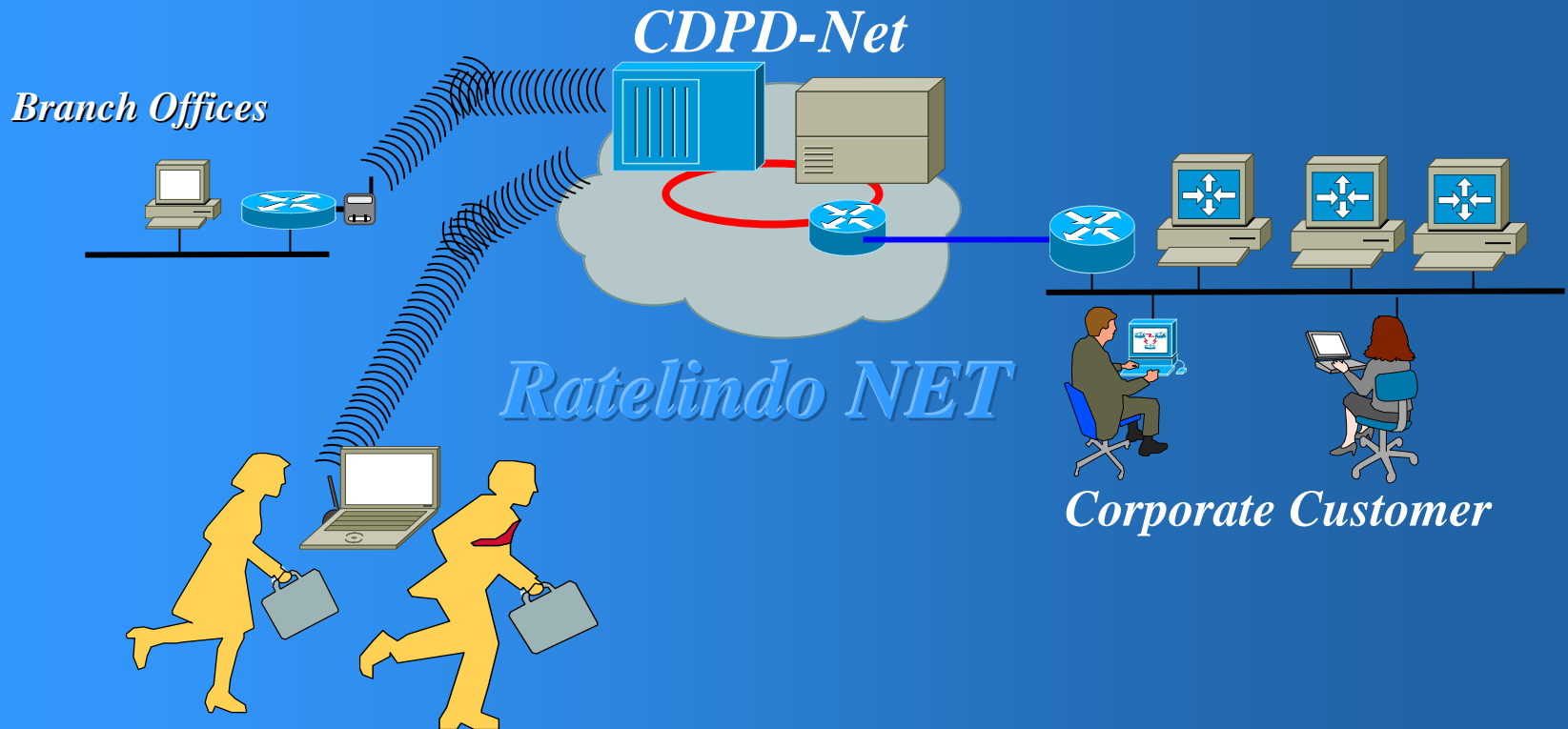

- *Mobile Engineers*
- *Mobile Executives*

PT. Praweda Ciptakarsa Informatika

N&T Division - SNA to TCP/IP Migration *Project*

Banking: Bank Universal

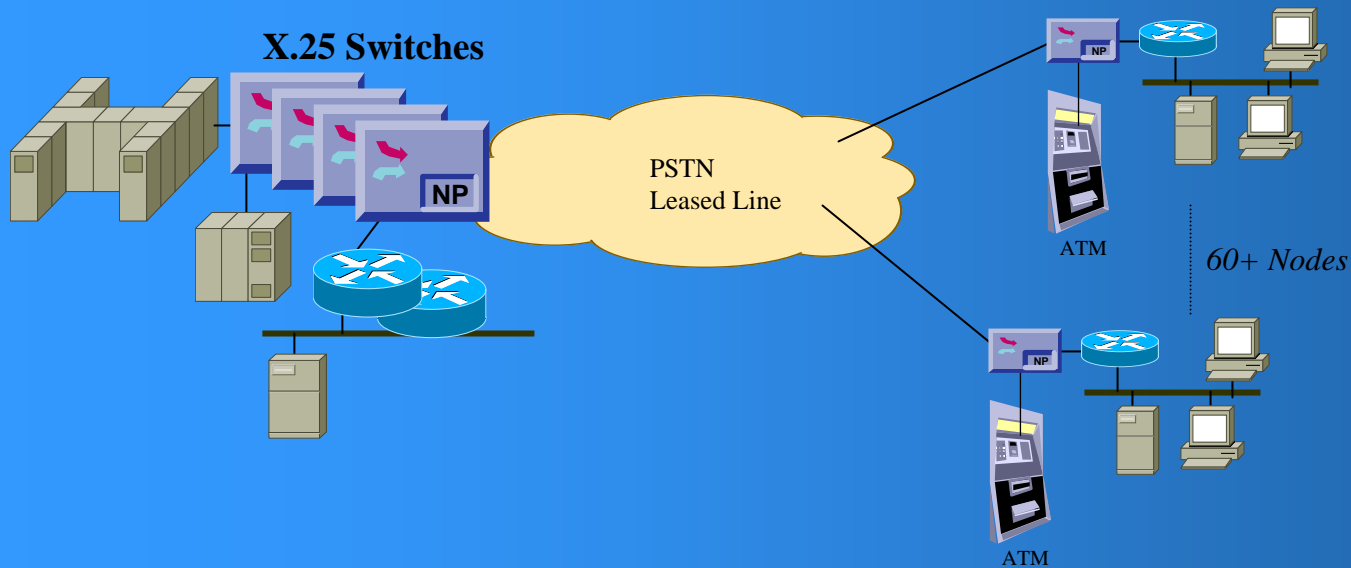

Business Transformation

Non-Transformed

Transformed

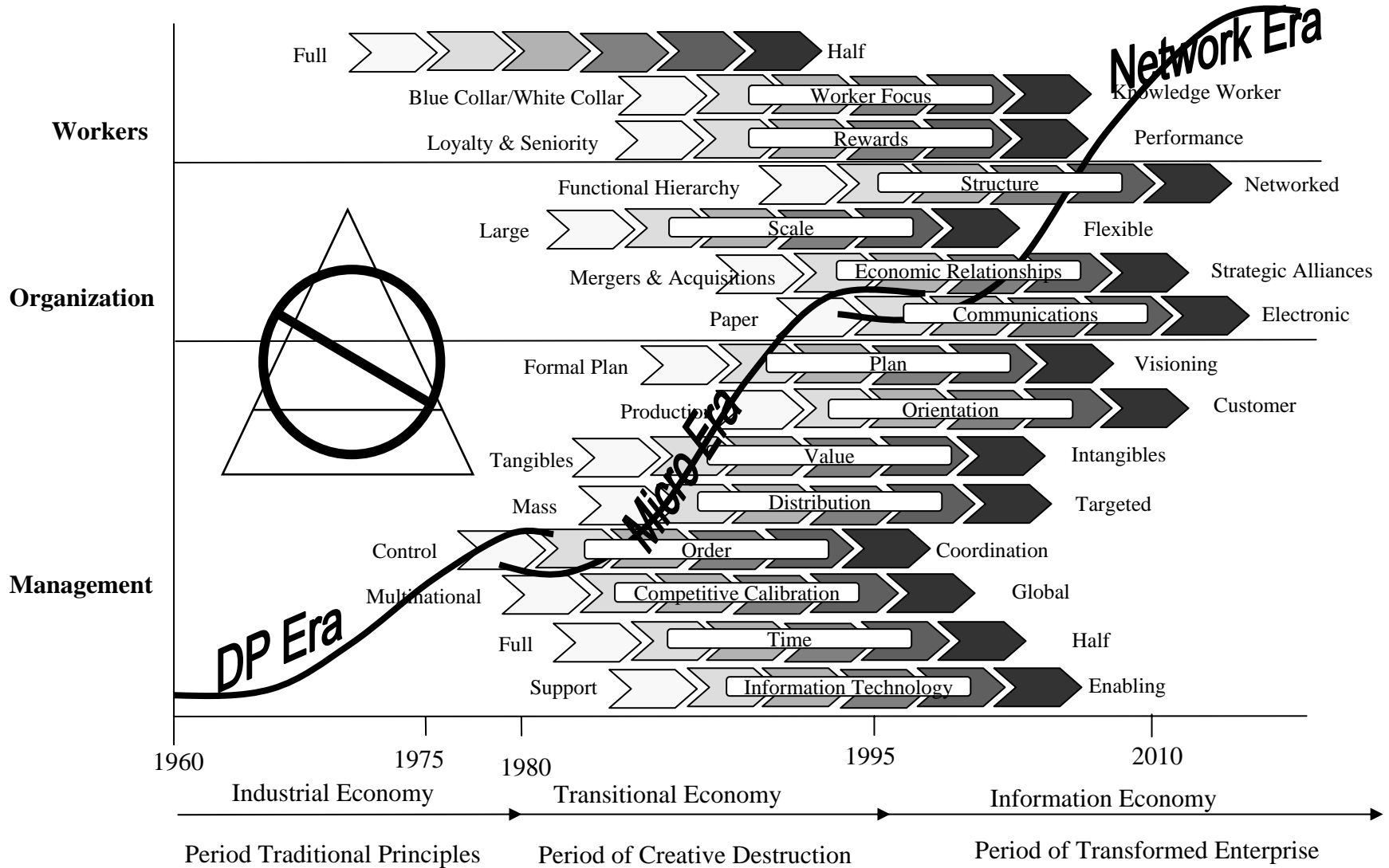

Source :Creative Destruction - Richard L.Nolan & David Crosson

Patterns of adoption

It takes time for a new technology to find
its true market

It takes time, too, for new business
models to emerge



Indonesia -

- key thrusts to prosperity

In the short and medium term, the way people adopt new technologies will be influenced by culture, convenience, and cost

It will also vary enormously from one country to the next



Asia-Pacific

Information Technology

Summit